

# BRICKMAN 300 PLASTIC

This version of BRICKMAN 300 with extended cylinder is designed for effective compaction of large amounts of tough material like pet and other plastic containers. The automated solution is time-saving and convenient. Due to a small footprint and low sound emission, BRICKMAN 300 can be placed indoors close to the source of waste.

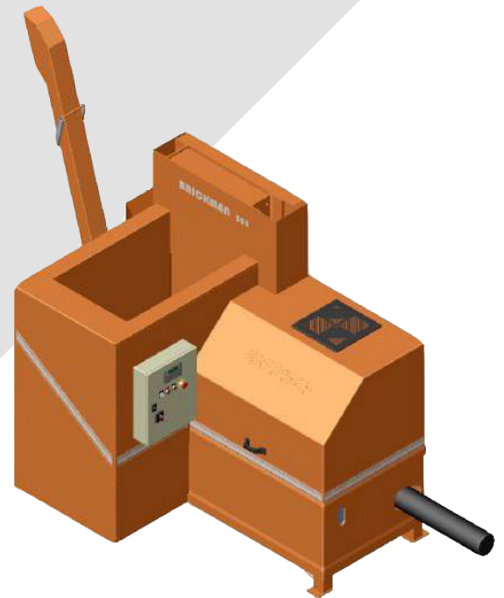

**AUTOMATIC  
SOLUTION**



**CAPACITY  
PET BOTTLES**

## ORWAK BENEFITS

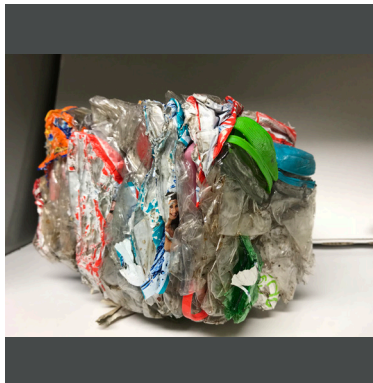

### **MORE PRODUCTIVE USE OF TIME**

Less time spent on waste handling, more time for your core activities!

### **MORE SPACE & ORDER**

Our balers rapidly minimize the space the waste takes up, keeping aisles free and tidy.

### **LESS COSTS, MORE VALUE**

More compaction = less waste volume to transport. Fewer transports required results in lower transportation costs and reduced CO<sub>2</sub> emissions. Sorting at source yields a higher quality of waste material for recycling.

## WHY BRICKMAN?

- Convenient fully automated compaction solution
- Impressive volume reduction of up to 20:1
- Placement opportunities indoors

**ORWAK**  
PART OF **SULO** GROUP

# BRICKMAN 300 PLASTIC

Turns large volume of material into compact briquettes for recycling

## CONVENIENT AND EFFICIENT

BRICKMAN offers time-saving and comfortable waste handling. The press can be fed while running, there is no lid or door to open when loading the material and the ready briquettes require no binding.

Furthermore, optional photocells can automate the start function. The material infeed and briquette outfeed are easy to integrate in system solutions.

## GREAT LOGISTICS

Thanks to BRICKMAN's compact dimensions and low sound emission, it can be placed indoors close to the waste disposal station.



## BRICKMAN 300 PLASTIC IS OPTIMIZED FOR:

### PLASTIC

- PET bottles
- Plastic containers

### CAPACITY

Up to 170 kg/h

## DESIGNED FOR PLASTIC

Thanks to the following features, this sturdy version of BRICKMAN 300 is especially designed for compaction of empty PET bottles and other plastic containers:

- Extension on the press cylinder
- Automatic greasing of the press plate
- Reinforced material in press chamber, press plate, cutting blades, guide piston and press loop

## OPTIONAL ACCESSORIES

BRICKMAN can be ordered with a number of accessories; different chute options, start systems, sound absorption plates as well as heating and cooling devices.

## DIMENSIONS & SPECIFICATIONS

### DIMENSIONS (mm)

A	B	C	D	E	F	G	H	I	J	K	L	M	N	O	P	Q	R
2270	1950	Ø145	425	1360	1500	1880	850	2190	660	3700	140	950	210	245	840	1440	600

### DIMENSIONS (mm)

S	T
825	1100

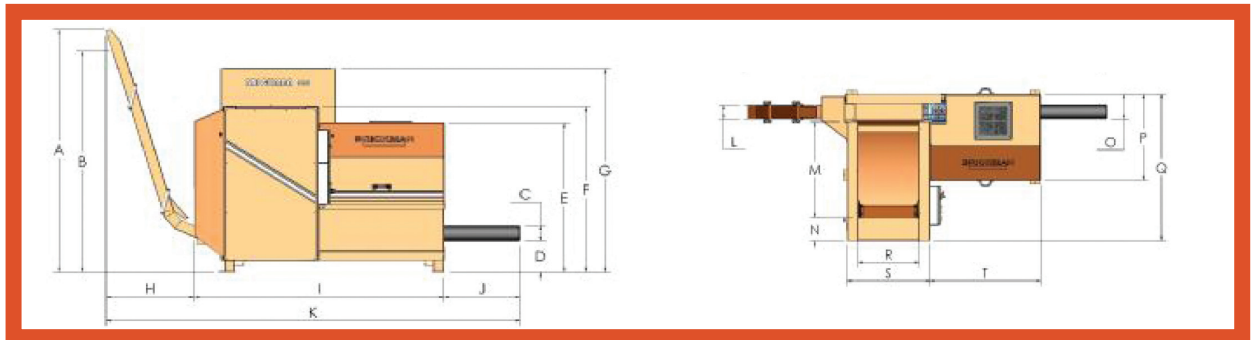

### TECHNICAL SPECIFICATIONS

MACHINE WEIGHT	PRESS FORCE	PRESSURE	HOPPER	BRIQUETTE SIZE	DENSITY*	NOISE LEVEL	PROTECTION CLASS	OPERATING POWER
1600 kg	25 ton 250 kN	Up to 500 kg/cm	0.75 m <sup>3</sup>	80x80x100-300 mm	Up to 600 kg/m <sup>3</sup>	68 db (A)	IP 55	400 V, 3-phase, 50 Hz** Fuse: 25 A (slow) Engine: 7.5 kW, Voltage 24 V

We reserve the right to make changes to specifications without prior notice. \* Density varies with type of material. \*\* Other voltages are available

## ORWAK AB

Svetsaregatan 4  
S-576 33 Sävsjö  
SWEDEN  
Tel: +46-(0)382-15700  
info@orwak.com

**ORWAK.COM**

**ORWAK**  
PART OF SULO GROUP